

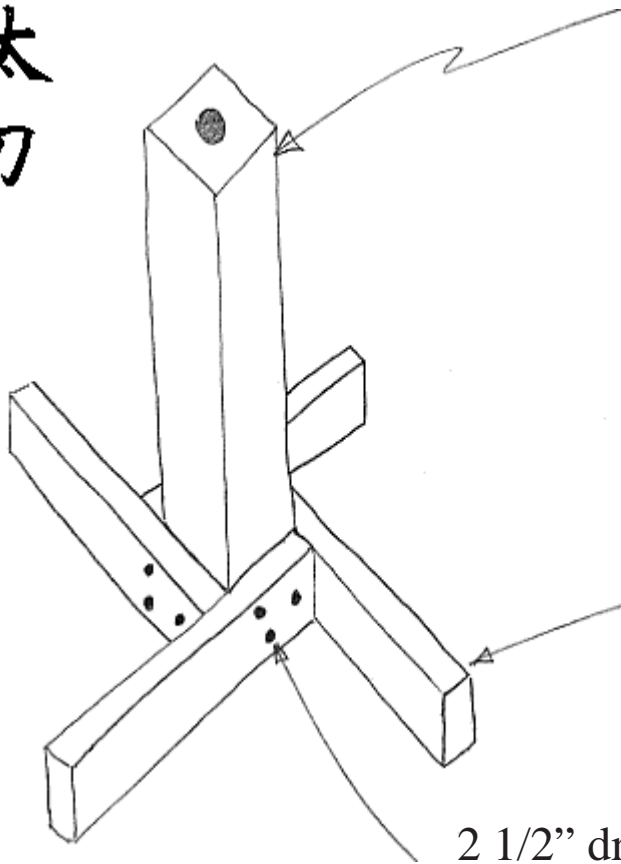

無限太刀



The peg can be made from any type of material. We prefer to use a 1" diameter oak dowel. Buy a 2' or 3' piece so you can make several pegs in case one is cut. Tapering one end will make it easier to slide the rolled tatami onto the peg.



(4x4 Post) The correct height for the upright can be determined by taking the measurement from the ground up to your groin. The average post height is approximately 30" to 34".

(2x4 Legs) Min. 18" - Max. 22"
Longer legs will make a more stable stand but can get in the way as you try to move around for different cuts.

2 1/2" drywall screws, lag bolts, or nails.

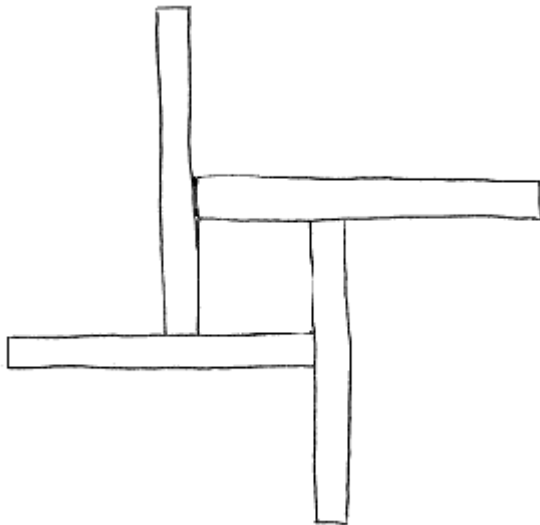

Bottom View

Materials List

- 4x4 Post, 28" to 36", 1 pc.
- 2x4 Legs, 18" to 22", 4 pcs.
- 3/4" or 1" diameter dowel, 1pc.
- Spade Drill, 3/4" or 1", 1 only
- 2 1/2" Screws, Lags, Nails, 12 pcs.
- Sandpaper, 80 to 120 grit, 2 or 3 sheets
- Stain or Oil Finish, 1 pint can